



65 USt



131 ft



151 ft



184 ft

The flexibility to make the difference

LTM 1055-3.2

Mobile crane
Grue mobile

LIEBHERR

Mobile and crawler cranes



Technical data

Caractéristiques technique

Dimensions	
Encombrement	3
Mobile crane	
Grue mobile	4-5
Counterweight	
Contrepoids	6
On-road driving	
Déplacement sur route	7
Jobsite driving	
Déplacement sur chantier	7
Crane data	
Dates de la grue	8
Boom/jib combinations	
Configurations de flèche	9
T	10-15
TK	16-21
TK	22-25
Equipment	
Equipement	26-27
Description of symbols	
Explication des symboles	28
Remarks	
Remarques	29

Dimensions

Encombrement

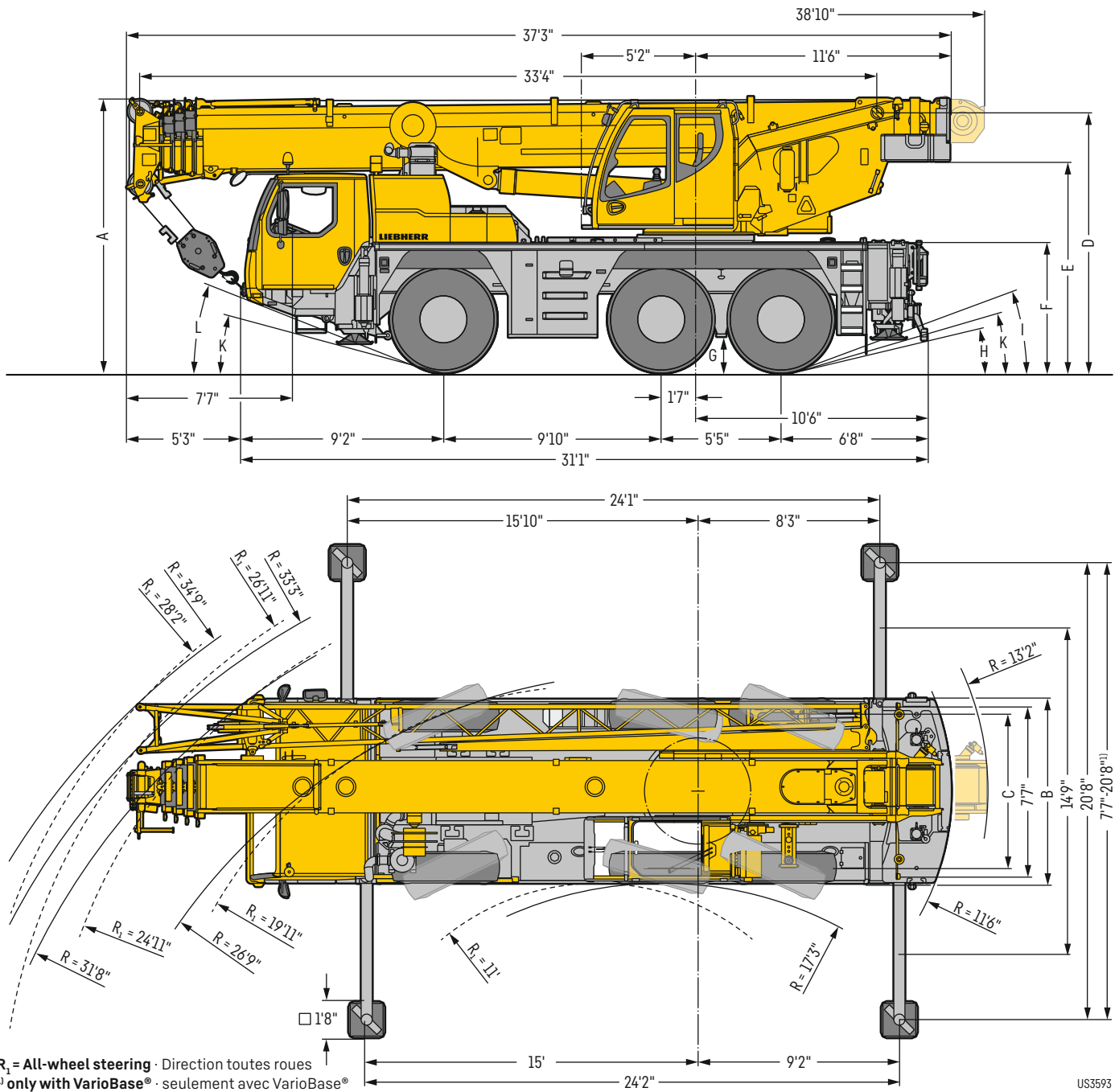

Dimensions · Encombrement

	A	A	B	C	D	E	F	G	H	I	K	L
		4" *										
445/95 R 25 (16.00 R 25)	12'4"	12'	8'4"	6'11"	11'8"	9'5"	5'9"	1'5"	12°	20°	15°	21°
525/80 R 25 (20.5 R 25)	12'4"	12'	8'10"	7'1"	11'8"	9'5"	5'9"	1'5"	12°	20°	15°	21°

* lowered · abaissé

LTM 1055-3.2





Hillstart Aid makes starting on gradients easier. Move off safely and easily without rolling backwards.

La fonction Hillstart-Aid facilite le démarrage en côte. Démarrage sûr et facile sans recul du véhicule.

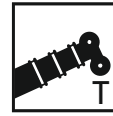

131 ft

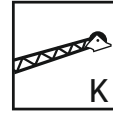

31 ft - 52 ft

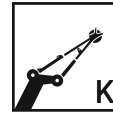

8 ft

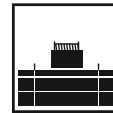

26,450 lb



270 kW (367 h.p.)

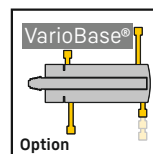
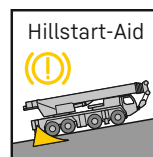

High performance boom with single cylinder system

Une flèche encore plus puissante avec un système à un vérin

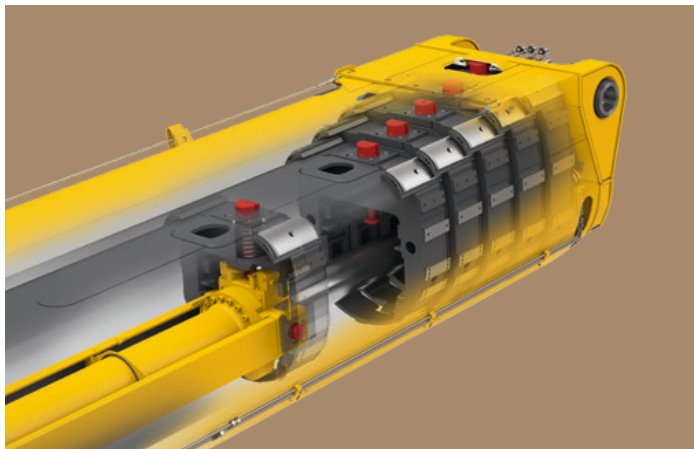

- Automatic fast cycle telescoping system TELEMATIK
- High capacities over the complete working range
- Système de télescopage séquentiel rapide automatique TELEMATIK
- Forces de levage élevées sur l'ensemble de la zone de travail

Counterweight

Contrepoids



26,450 lb axle load
26,450 lb de charge par essieu

Technically transportable
Transport techniquement simplifié

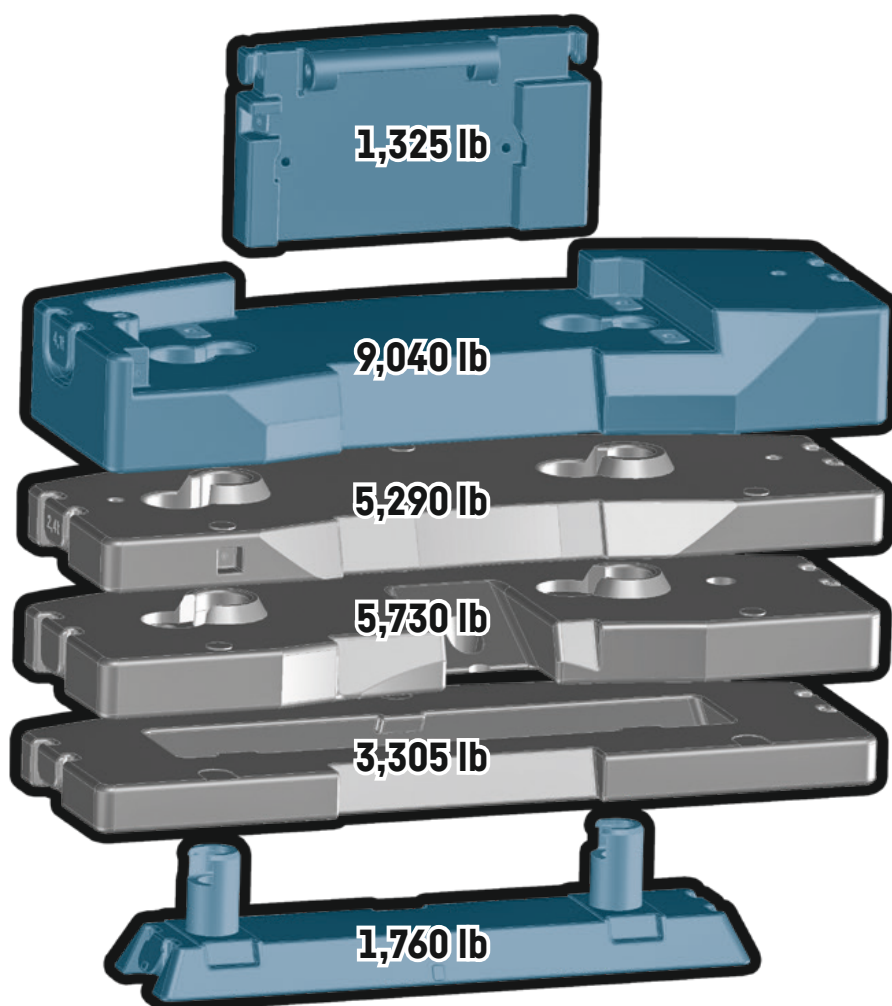

On-road driving

Déplacement sur route

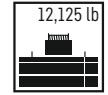
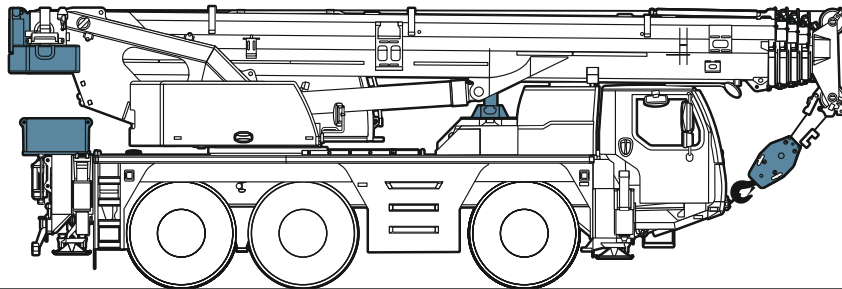

≤ 79,350 lb

≤ 26,450 lb ≤ 26,450 lb ≤ 26,450 lb

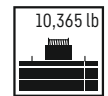
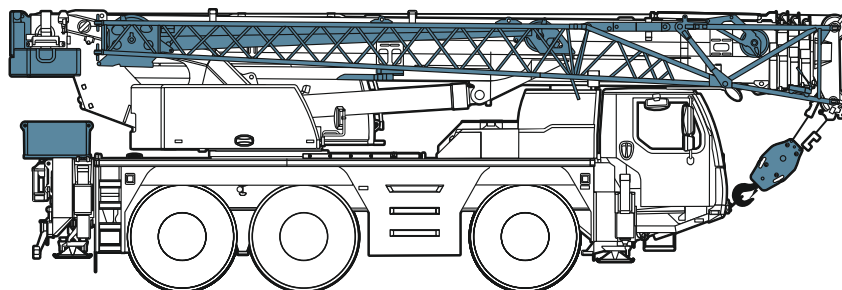

≤ 79,350 lb

≤ 26,450 lb ≤ 26,450 lb ≤ 26,450 lb

Jobsite driving

Déplacement sur chantier

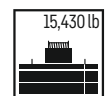
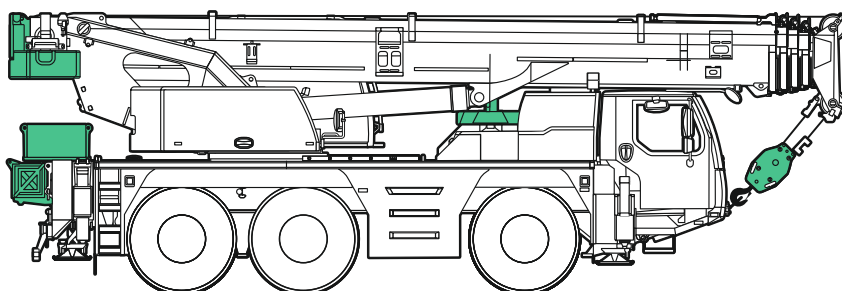

≤ 83,800 lb

≤ 28,660 lb ≤ 28,660 lb ≤ 28,660 lb

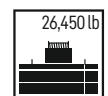
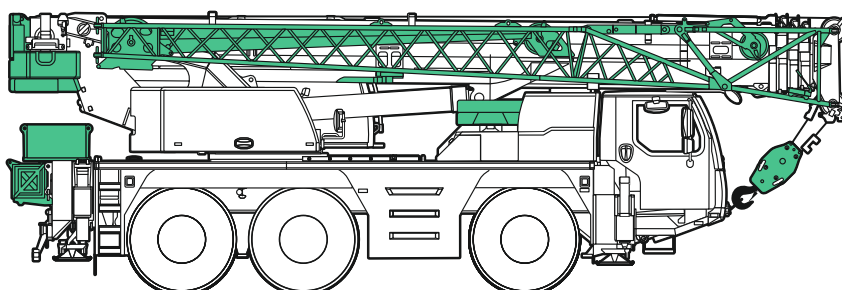

≤ 96,000 lb





≤ 32,000 lb ≤ 32,000 lb ≤ 32,000 lb

US3594









Crane data

Dates de la grue

Hook block - Moufles à crochet

			
121,250 lb	7	14	880 lb
101,630 lb	5	10	880 lb
66,580 lb	3	7	620 lb
29,320 lb	1	3	430 lb
9,920 lb	-	1	165 lb

Crane carrier - Châssis porteur









	 min.	 max.	 %		
445/95 R 25 (16.00 R 25)	0.4	53	> 60%		12 / R2
525/80 R 25 (20.5 R 25)	0.4	53	> 60%		4 / R2

Theoretical gradeability - aptitude théorique en pente

Max. supporting forces - Forces d'appui max.

		
F _{max}	69,700 lb	110,230 lb

Crane superstructure - Partie tournante

			
 0 - 427 ft/min single line - au brin simple	15 mm	722 ft	10,100 lb
 0 - 427 ft/min single line - au brin simple	15 mm	722 ft	10,100 lb
 0 - 1.3 rpm			
 approx. 60 seconds to reach 83° boom angle env. 60 s jusqu'à 83°			
 approx. 270 seconds for boom extension from 33 ft - 131 ft env. 270 s pour passer de 33 ft - 131 ft			

Boom/jib combinations

Configurations de flèche

- T** **Telescopic boom** · Flèche télescopique
- K** **Mechanical swing away jib** · Flechette pliante mecanique
- K** **Assembly jib** · Fléchette de montage

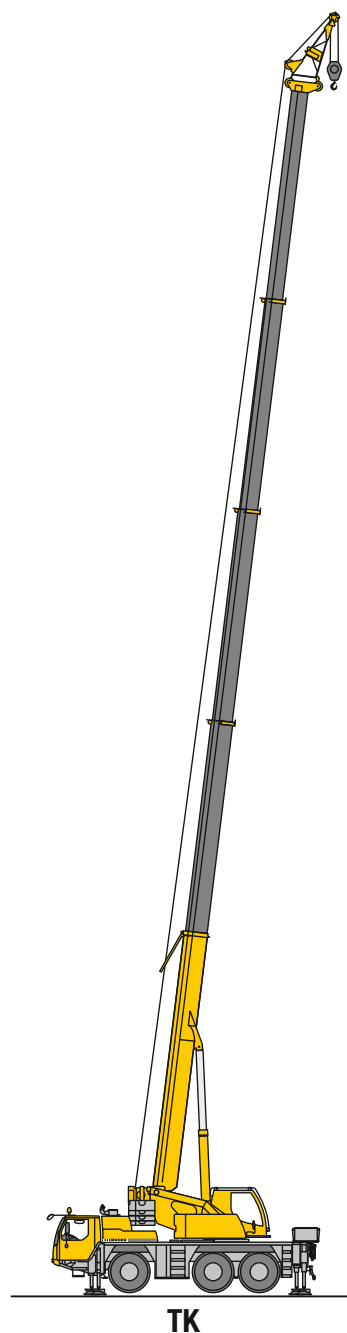
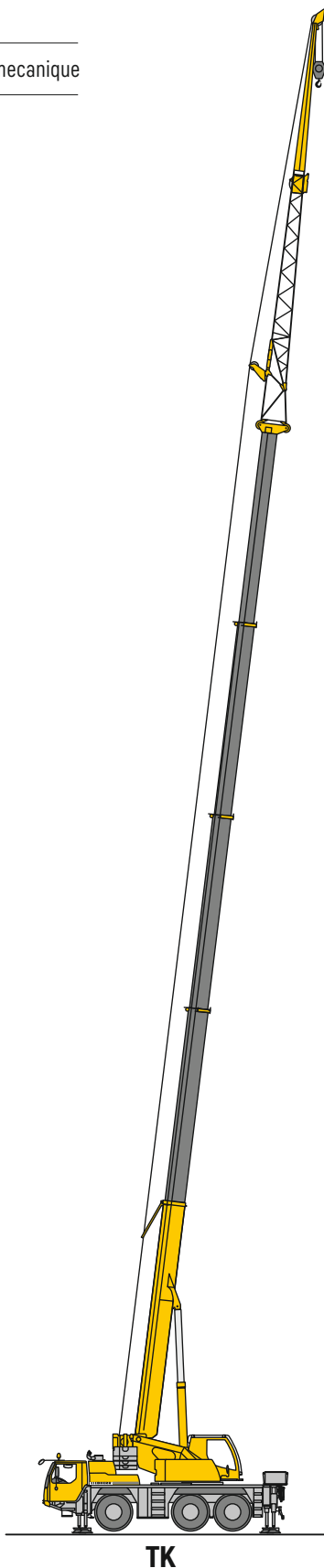
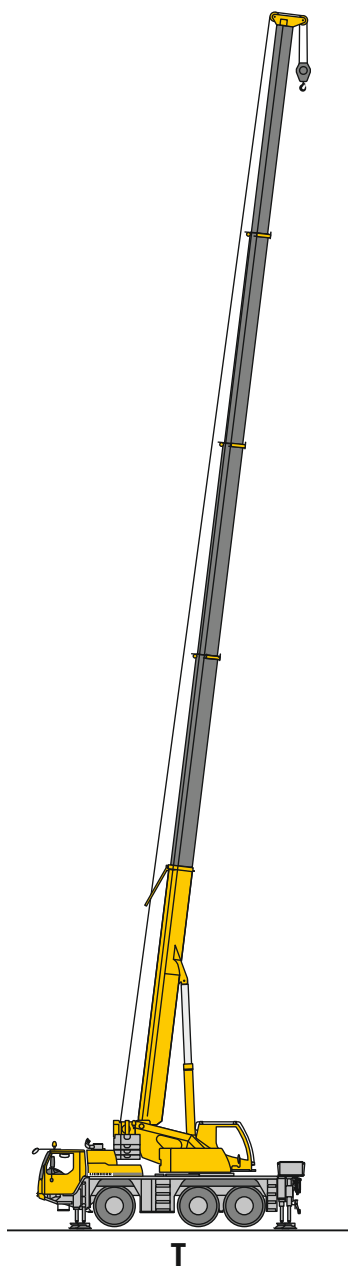

Lifting heights

Hauteurs de levage

T

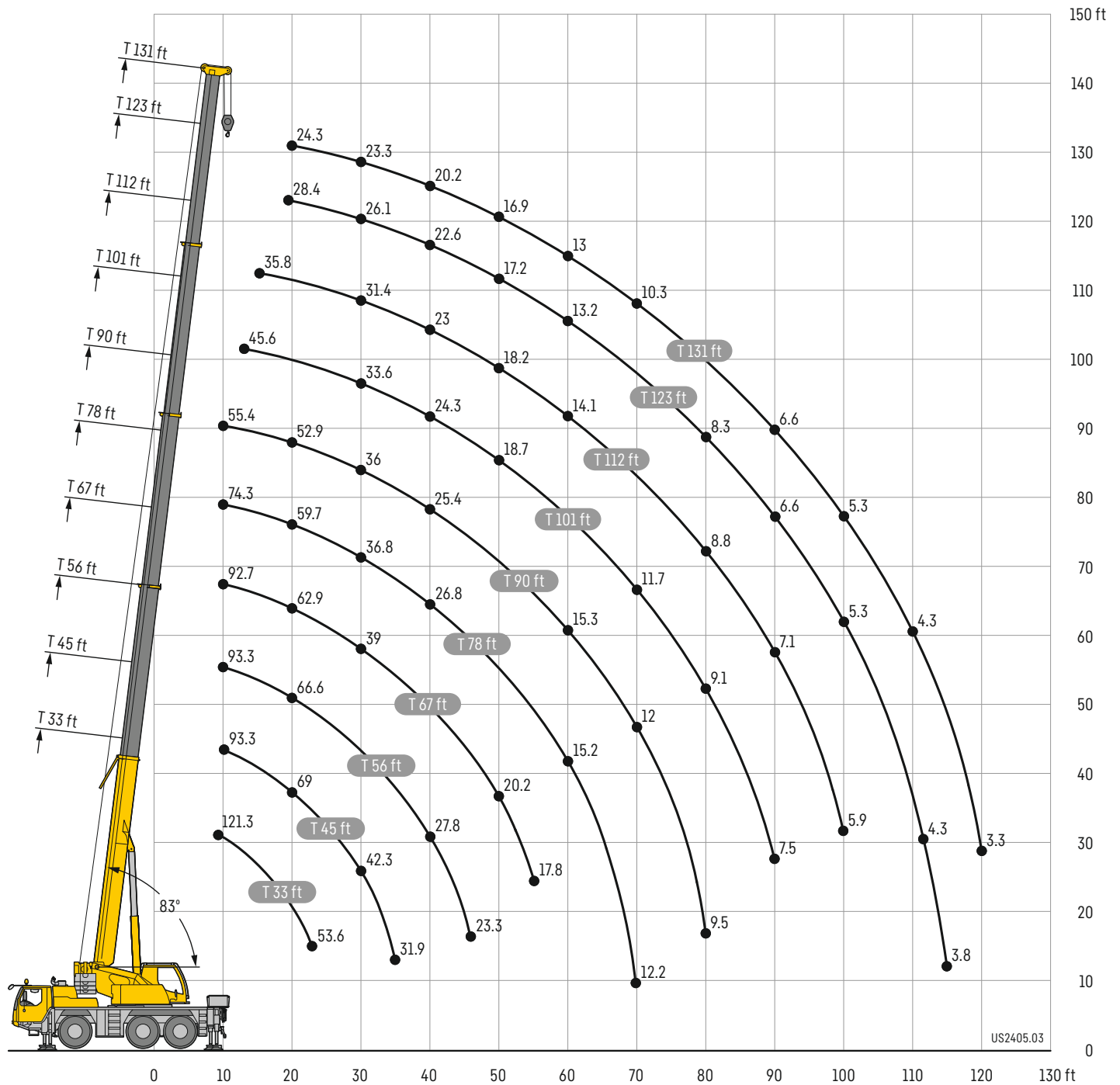

Lifting capacities

Forces de levage

T



	33 ft	45 ft	56 ft	67 ft	78 ft	90 ft	101 ft	112 ft	123 ft	131 ft	
9	121.3										9
10	121.3	93.3	93.3	93.3	92.7	74.3	55.4				10
11	121.2	93.3	93.3	93.3	91.8	74.8	56				11
12	107.3	93.3	93.3	92.4	89.1	75.3	56.6				12
13	100.2	93.3	92.2	87.2	83.5	75.1	57.1	45.6			13
14	93.6	92.3	89.5	82.5	78.4	74.2	57.4	46			14
15	87.6	87.6	84.6	78.8	74.9	72.3	57.6	46.4	35.8		15
16	82.8	82.8	80.9	76.2	71.6	68.2	57.4	46.5	36.1		16
17	79.4	79.4	77.1	72.7	68.9	65.6	56.5	46.1	36.3		17
18	76	75.9	74.3	70.5	66.9	63.5	55.4	45.6	36.5	28.4	18
19	72.7	72.4	71.7	68.5	64.9	61.5	54.2	45.1	36.4	28.5	19
20	69.5	68.8	69	66.6	62.9	59.7	52.9	44.3	36.3	28.5	20
22	62.6	61.8	62.5	60	58	54.5	50.2	42.4	35.5	28.5	22
24	53.6	53.6	56.9	54.7	51.9	48.7	45.9	40.6	34.5	28.1	24
26		51.4	49.3	46.8	44.1	41.6	38.9	33.5	27.5	24.1	26
28		46.5	44.8	42.6	40.2	38.6	36.6	32.4	26.8	23.8	28
30		42.3	40.9	39	36.8	36	33.6	31.4	26.1	23.3	30
32		38.5	37.7	35.9	34	33.6	31	30.1	25.4	22.9	32
34		35	34.8	33.2	31.7	31.1	29.2	28.3	24.7	22.2	34
36		31.9	32.4	30.8	30.2	29	27.8	26.3	24	21.5	36
38			30	28.7	28.6	27.1	25.9	24.6	23.3	20.8	38
40			27.8	27	26.8	25.4	24.3	23	22.6	20.2	40
45			23.3	23.1	23.1	21.8	21.5	20.8	19.8	18.8	45
50				20.2	20.2	18.9	18.7	18.2	17.2	16.9	50
55				17.8	17.4	16.9	16.5	16	15	14.8	55
60					15.2	15.3	14.7	14.1	13.2	13	60
65					13.4	13.5	13.2	12.6	11.7	11.5	65
70					12.2	12	11.7	11.3	10.4	10.3	70
75						10.8	10.4	10.1	9.3	9.2	75
80						9.5	9.1	8.8	8.3	8.2	80
85							8.2	7.9	7.4	7.4	85
90							7.5	7.1	6.6	6.6	90
95								6.5	5.9	5.9	95
100								5.9	5.3	5.3	100
105									4.8	4.7	105
110									4.3	4.3	110
115									3.8	3.8	115
120										3.3	120

* 0° = over rear - sur arrière

t_204_01140_01_000 / t_204_01142_01_000

Lifting capacities

Forces de levage

T

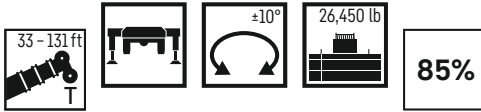

	33 ft	45 ft	56 ft	67 ft	78 ft	90 ft	101 ft	112 ft	123 ft	131 ft	
10	93.3	93.3	93.1	84.2	67.6	50.3					10
11	93.3	93.3	92.4	83.7	68	50.9					11
12	93.3	93.3	92.2	83	68.4	51.5					12
13	93.2	92.2	86.9	81.8	68.3	51.9	41.4				13
14	92.2	89.5	82.5	78.2	67.9	52.2	41.8				14
15	87.5	84.6	78.8	73.8	67.5	52.3	42.1	32.6			15
16	82.8	80.2	75.3	70.3	67.1	52.1	42.2	32.8			16
17	79.3	77.1	72.1	68.5	65.5	51.4	41.9	33			17
18	75.8	74.3	70.5	66.6	63.5	50.4	41.5	33.2	25.8		18
19	72.2	71.7	68.5	64.7	61.5	49.3	41	33.1	25.9	22.1	19
20	69	69.2	66.6	62.6	59.7	48.1	40.3	33	25.9	22.2	20
22	61.9	62.7	60	58.1	54.5	45.6	38.6	32.2	25.9	22.2	22
24	52.9	53.9	53.3	51.9	48.7	43.4	36.9	31.4	25.5	22.3	24
26		47.6	47.5	46.8	44.1	40.9	35.4	30.5	25	22	26
28		42.2	42.9	42.5	40.2	37.8	33.9	29.5	24.4	21.6	28
30		37.8	38.4	38.4	36.8	34.8	32.4	28.5	23.7	21.2	30
32		34.1	34.8	34.6	33.8	32.7	30.8	27.6	23.1	20.8	32
34		31	31.5	31.5	31	30.6	28.7	26.6	22.5	20.2	34
36		28.3	28.9	28.9	28.3	28.9	26.7	25.7	21.8	19.5	36
38			26.7	26.6	26.4	26.8	24.9	24.4	21.2	18.9	38
40			24.6	24.6	25.1	24.8	23.7	23	20.6	18.4	40
45			20.6	20.5	21.2	20.7	20.4	19.7	19	17.2	45
50				18.2	18.1	17.6	17.8	17.6	17.2	16	50
55				15.8	15.7	15.4	15.4	15.4	15	14.8	55
60					13.7	13.9	13.6	13.4	13	13	60
65					12.2	12.3	12.1	11.9	11.4	11.4	65
70					11	11	10.7	10.5	10.1	10	70
75						9.9	9.6	9.4	8.9	8.8	75
80						8.9	8.6	8.4	7.9	7.9	80
85							7.8	7.6	7.1	7.1	85
90							7	6.8	6.3	6.3	90
95								6.1	5.6	5.6	95
100								5.5	5	5	100
105									4.5	4.5	105
110									4	4	110
115									3.6	3.6	115
120										3.2	120

t_204_12001_00_000

Lifting capacities

Forces de levage

T



	33 ft	45 ft	56 ft	67 ft	78 ft	90 ft	101 ft	112 ft	123 ft	131 ft	
10	93.3	93.3	93.3	92.7	74.3	55.4					10
11	93.3	93.3	93.3	91.8	74.8	56					11
12	93.3	93.3	92.4	89.1	75.3	56.6					12
13	93.3	92.2	87.2	83.5	75.1	57.1	45.6				13
14	92.3	89.5	82.5	78.4	74.2	57.4	46				14
15	87.5	84.6	78.8	74.9	72.1	57.6	46.4	35.8			15
16	82	80.8	75.1	71.4	66.6	57.4	46.5	36.1			16
17	77.1	75.7	69.9	66.8	61.7	55.7	46.1	36.3			17
18	72.4	69.4	65.7	62	57.3	53.1	45.6	36.5	28.4		18
19	67.9	64.6	61.4	57.7	53.4	49.9	45.1	36.4	28.5	24.3	19
20	63.6	60.4	57.4	53.8	49.9	47.6	43.6	36.3	28.5	24.4	20
22	55.6	52.7	50.3	47.4	44.6	42.9	39.6	35.5	28.5	24.5	22
24	48.5	46.6	44.6	42.2	39.9	38.7	36.3	34.2	28.1	24.5	24
26		41.7	40.1	38	37.2	35.2	33.3	31.4	27.5	24.1	26
28		37.6	36.3	34.5	34.1	31.9	30.4	28.6	26.8	23.8	28
30		34.3	33.1	31.5	31.2	29.3	28.3	27.2	25.6	23.3	30
32		31.1	30.4	29.6	28.7	26.9	26.2	25.3	23.8	22.7	32
34		28.2	28	27.7	26.4	25.1	24.3	23.4	22	21.5	34
36		25.7	25.9	25.6	24.4	23.8	22.7	21.7	20.4	19.9	36
38			24.1	23.8	22.7	22.2	21.1	20.2	19	18.5	38
40			22.3	22.2	21.1	20.7	19.7	18.8	17.7	17.3	40
45			18.2	18.8	18.1	17.6	16.7	16	14.9	14.7	45
50				15.7	15.6	15.2	14.3	13.7	12.8	12.5	50
55				13.5	13.4	13.2	12.5	11.9	11	10.8	55
60					11.6	11.6	10.9	10.4	9.5	9.4	60
65					10.1	9.9	9.5	9.1	8.3	8.2	65
70					8.8	8.7	8.3	8	7.2	7.1	70
75						7.7	7.3	7	6.4	6.2	75
80							6.9	6.5	6.2	5.6	80
85								5.8	5.5	4.9	85
90								5.2	4.9	4.3	90
95									4.3	3.7	95
100									3.8	3.2	100
105										2.7	105
110										2.3	110
115										1.9	115
120										1.6	120

t_204_01143_01_000

Lifting capacities

Forces de levage

T

33 - 131 ft     **85%**

	33 ft	45 ft	56 ft	67 ft	78 ft	90 ft	101 ft	112 ft	123 ft	131 ft	
10	93.3	93.3	93.1	84.2	67.6	50.3					10
11	93.3	93.3	92.4	83.7	68	50.9					11
12	93.3	93.3	92.2	83	68.4	51.5					12
13	93.2	92.2	86.9	81.8	68.3	51.9	41.4				13
14	91.6	89.5	82.5	78.2	67.9	52.2	41.8				14
15	86.4	84.6	78.8	73.8	67.4	52.3	42.1	32.6			15
16	81.7	79.8	74	70.3	65.8	52.1	42.2	32.8			16
17	77.2	75.8	69.3	66.7	61.7	51.4	41.9	33			17
18	72.3	69.4	64.8	62	57.3	50.3	41.5	33.2	25.8		18
19	66.5	64.1	59.8	57.7	53.4	49	41	33.1	25.9	22.1	19
20	60.6	59.5	56.5	53.8	49.9	46.6	40.3	33	25.9	22.2	20
22	50.4	52.2	50.3	47.4	44.3	41.9	38.6	32.2	25.9	22.2	22
24	42.9	44.7	44.6	42.3	39.5	37.9	35.5	31.4	25.5	22.3	24
26		38.9	39.7	38	35.8	35.2	32.1	30.4	25	22	26
28		34.3	35	34.5	32.9	32	30	28.7	24.4	21.6	28
30		30.6	31.3	31.2	31	29.4	28	26.3	23.7	21.2	30
32		27.5	28.2	28.1	28.7	27	25.7	24.2	23.1	20.8	32
34		24.9	25.5	25.6	26.3	25	24	23	22.1	20.2	34
36		22.7	23.5	24.2	24	23.2	22.8	21.9	20.8	19.5	36
38			21.6	22.2	22.1	21.5	21.2	20.6	19.4	18.8	38
40			19.9	20.6	20.4	20.3	19.9	19.2	18.1	17.8	40
45			16.5	17.1	17	17.2	16.9	16.5	15.4	15.2	45
50				14.5	14.5	14.6	14.3	14.1	13.3	13.1	50
55				12.5	12.6	12.6	12.3	12.1	11.5	11.4	55
60					10.9	11	10.7	10.5	10	9.9	60
65					9.6	9.6	9.3	9.1	8.5	8.4	65
70					8.5	8.5	8.2	8	7.4	7.4	70
75						7.5	7.3	7	6.5	6.4	75
80							6.8	6.4	6.2	5.7	80
85								5.7	5.5	5	85
90								5.1	4.8	4.4	90
95									4.2	3.8	95
100									3.7	3.3	100
105										2.8	105
110										2.4	110
115										2.1	115
120										1.7	120

t_204_12003_00_000

33 - 131 ft     **85%**

	33 ft	45 ft	56 ft	67 ft	78 ft	90 ft	101 ft	112 ft	123 ft	131 ft	
10	93.3	93.3	93.1	84.2	67.6	50.3					10
11	93.3	93.3	92.4	83.7	68	50.9					11
12	93	91.9	92.2	83	68.4	51.5					12
13	88.9	88.9	86.9	81.8	68.3	51.9	41.4				13
14	83.8	83.7	81.8	77.3	67.9	52.2	41.8				14
15	78.2	78.3	76.1	71	67.1	52.3	42.1	32.6			15
16	73.3	74	70.2	67.6	62.2	52.1	42.2	32.8			16
17	68.7	69.4	65.3	62.5	57.7	51.2	41.9	33			17
18	64.2	64.8	60.6	58	53.5	49.6	41.5	33.2	25.8		18
19	60.2	59.9	57.5	54	49.9	46.4	41	33.1	25.9	22.1	19
20	55.9	56.3	53.7	50.3	46.6	43.8	40.2	33	25.9	22.2	20
22	47.1	48.8	47	44.3	41.3	39.8	36.8	32.2	25.9	22.2	22
24	40	41.8	41.7	39.4	37.2	36.1	33	31.2	25.5	22.3	24
26		36.3	37.1	35.4	34.6	32.7	30.9	29	25	22	26
28		32	32.7	32.1	31.7	29.6	28	26.2	24.4	21.6	28
30		28.5	29.2	29.1	28.9	27	25.8	24.8	23.4	21.2	30
32		25.6	26.4	26.8	26.4	24.7	24	23.2	21.8	20.7	32
34		23.1	23.9	24.6	24.3	22.8	22.3	21.5	20.1	19.6	34
36		20.9	21.7	22.4	22.3	21.8	20.8	19.8	18.6	18.2	36
38			19.8	20.5	20.3	20.4	19.3	18.4	17.3	16.9	38
40			18.2	18.9	18.7	18.9	18	17.1	16	15.7	40
45			14.9	15.5	15.5	15.6	15.2	14.5	13.5	13.2	45
50				13	13	13.1	12.8	12.4	11.5	11.3	50
55				11.1	11.1	11.2	10.9	10.7	9.8	9.7	55
60					9.6	9.6	9.3	8.9	8.3	8.2	60
65					8.3	8.3	8	7.7	7.1	7.1	65
70					7.3	7.3	7	6.7	6.1	6.1	70
75						6.4	6.1	5.8	5.3	5.2	75
80							5.7	5.3	4.6	4.5	80
85								4.6	4.4	3.9	85
90							4	3.8	3.3	3.3	90
95									3.3	2.8	95
100									2.8	2.3	100
105									1.9	1.9	105

t_204_01009_00_000

Lifting capacities

Forces de levage

T



	33 ft	45 ft	56 ft	67 ft	78 ft	90 ft	101 ft	112 ft	123 ft	131 ft	
10	93.3	93.3	93.1	84.2	67.6	50.3					10
11	93.3	93.3	92.4	83.7	68	50.9					11
12	93.3	93.3	92.2	83	68.4	51.5					12
13	93.1	92.2	86.9	81.8	68.3	51.9	41.4				13
14	90.8	89.5	81.8	77.3	67.9	52.2	41.8				14
15	85.7	83.6	76.1	71	67.1	52.3	42.1	32.6			15
16	80.8	76.5	70.2	67.6	62.2	52.1	42.2	32.8			16
17	75.7	70.9	65.3	62.5	57.7	51.2	41.9	33			17
18	69.9	64.9	60.6	58	53.5	49.6	41.5	33.2	25.8		18
19	62.6	59.9	57.5	54	49.9	46.4	41	33.1	25.9	22.1	19
20	56.6	56.3	53.7	50.3	46.6	43.8	40.2	33	25.9	22.2	20
22	47.1	48.8	47	44.3	41.3	39.8	36.8	32.2	25.9	22.2	22
24	40	41.8	41.7	39.4	37.2	36.1	33	31.2	25.5	22.3	24
26		36.3	37.1	35.4	34.6	32.8	31	29.1	25	22	26
28		32	32.7	32.1	31.8	29.7	28.3	26.6	24.4	21.6	28
30		28.5	29.2	29.1	29.1	27.3	26	24.9	23.7	21.2	30
32		25.6	26.4	26.8	26.7	25.1	24.5	23.6	22.3	20.8	32
34		23.2	23.9	24.7	24.5	23.1	22.8	22	20.6	20	34
36		21.1	21.9	22.5	22.4	22.1	21.3	20.4	19.2	18.8	36
38			20.1	20.7	20.5	20.7	19.9	19.1	17.9	17.5	38
40			18.5	19.1	19	19.2	18.6	17.8	16.7	16.4	40
45			15.3	15.9	15.9	16	15.7	15.2	14.2	13.9	45
50				13.4	13.5	13.5	13.2	13	12.2	12	50
55				11.6	11.6	11.6	11.3	11.2	10.5	10.3	55
60					10	10.1	9.8	9.5	8.9	8.8	60
65					8.8	8.8	8.5	8.2	7.7	7.6	65
70					7.8	7.8	7.5	7.2	6.7	6.6	70
75						6.9	6.6	6.3	5.8	5.7	75
80							6.1	5.8	5.5	5.1	80
85								5.1	4.9	4.4	85
90								4.5	4.2	3.8	90
95									3.7	3.2	95
100									3.2	2.7	100
105										2.3	105
110										1.9	110
115										1.6	115

t_204_12004_00_000



	33 ft				45 ft				
	26,450 lb	15,430 lb	12,125 lb	12,125 lb	26,450 lb	15,430 lb	12,125 lb	12,125 lb	
10	30.5	22.9	20.6		28.1	21.2	19.2		10
11	28.1	20.9	18.8		26.1	19.6	17.7		11
12	25.4	18.8	16.9		24.5	18.2	16.4		12
13	23	16.9	15.2		22.6	16.8	15.2		13
14	21.1	15.3	13.8		21	15.4	14		14
15	19.3	14	12.6		19.2	14.2	12.9		15
16	17.5	12.9	11.6		17.6	13.1	11.9		16
17	16.1	11.8	10.6		16.3	12.2	11		17
18	14.9	11	9.7		15.1	11.3	10.1		18
19	13.9	10.2	8.7	8.3	14.2	10.5	9.1		19
20	13	9	8.1	7.7	13.3	9.6	8.4		20
22	11.5	7.9	6.8	6.5	11.8	8.3	7.3	6.5	22
24	10.3	6.8	5.6	5.5	10.5	7.3	6.5	5.7	24
26					9	6.4	5.7	5.4	26
28					8.2	5.7	5	4.7	28
30					7.4	5.1	4.2	3.9	30
32					6.8	4.5	3.5	3.2	32
34					6.2	3.8	2.7	2.5	34
36					5.7	3.2	2.3	2.2	36

0° = over rear - sur arriere

t_204_01113_01_000 / 01115_01_000 / 01118_01_000 / 01136_01_001
t_204_13801_01_000 / 13803_01_000 / 13806_01_000 / 13906_01_001

Lifting heights

Hauteurs de levage

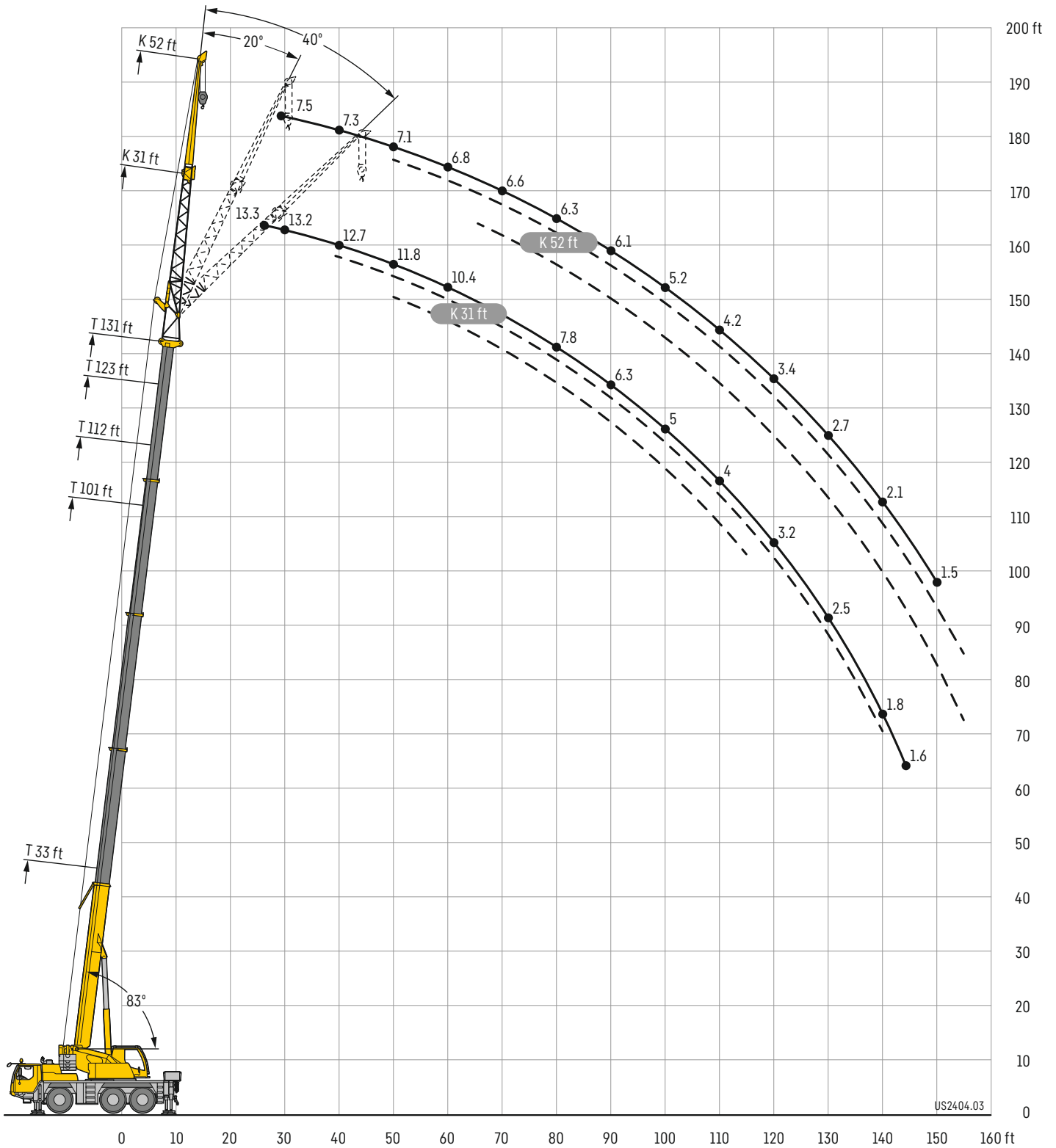

US2404.03

Lifting capacities

Forces de levage

TK

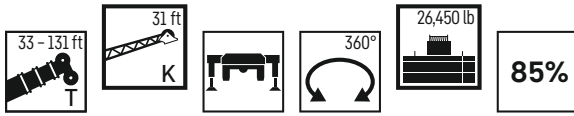

	33 ft			101 ft			112 ft			123 ft			129 ft			131 ft			
	0°	20°	40°	0°	20°	40°	0°	20°	40°	0°	20°	40°	0°	20°	40°	0°	20°	40°	
10	19.3																		10
11	18.8	17.6																	11
12	18.4	17.4																	12
13	18	17																	13
14	17.6	16.7																	14
15	17.2	16.4																	15
16	16.8	16.1																	16
17	16.4	15.8		19.8															17
18	16	15.5		19.8															18
19	15.6	15.2	13.9	19.8															19
20	15.2	15	13.7	19.8			18												20
22	14.4	14.4	13.3	19.8			17.9												22
24	13.7	14	12.9	19.8			17.7			14.9			13.5						24
26	12	13.5	12.5	19.7	17		17.6			14.9			13.6			13.3			26
28	10	13.1	12.2	19.4	16.7		17.5	15.4		14.8			13.6			13.3			28
30	9.7	12.7	11.9	19	16.4		17.3	15.3		14.7			13.5			13.2			30
32	9.7	12.3	11.6	18.5	16.1		17.1	15		14.7			13.5			13.2			32
34	8.9	11.9	11.3	18.1	15.8	13.5	16.9	14.8		14.6	13.4		13.4			13.1			34
36	8.1	11.6	10.9	17.7	15.5	13.3	16.7	14.6		14.5	13.3		13.2	12.6		13			36
38	7.3	11.2	10.3	17.3	15.2	13.1	16.6	14.4	12.7	14.3	13.2		13.1	12.5		12.9	12.3		38
40	6.7	10.9	10.1	16.9	15	13	16.4	14.2	12.6	14.1	13		12.9	12.4		12.7	12.2		40
45	5.1	9.8	9.7	15.9	14.4	12.6	15.9	13.7	12.2	13.6	12.7	11.6	12.5	12		12.3	11.9		45
50	4	9.3		15	13.9	12.2	15.3	13.3	11.9	12.9	12.3	11.3	12	11.5	10.8	11.8	11.4	10.5	50
55	2.9			14.1	13.4	11.9	14.3	12.9	11.6	12.3	11.7	11.1	11.5	10.8	10.2	11.1	10.8	10.2	55
60				12.7	12.9	11.5	12.6	12.5	11.3	11.8	10.9	10.3	10.8	10	9.8	10.4	10	9.7	60
65				10.2	12.2	11.2	11.2	11.8	11	11.2	10.2	10	10.1	9.5	9.4	9.9	9.5	9.4	65
70				9.7	11.3	10.8	10.2	10.6	10.4	9.9	9.8	9.6	9.5	9.2	9	9.4	9.1	9	70
75				9.4	10.2	10.1	9.6	9.4	9.8	8.9	9.3	9.2	8.8	8.8	8.7	8.7	8.8	8.7	75
80				8.4	9.1	9.5	8.7	8.9	8.8	8	8.5	8.8	7.9	8.4	8.3	7.8	8.2	8.3	80
85				7.5	8.3	8.5	7.9	8.3	8.4	7.1	7.6	8	7.1	7.5	7.9	7	7.4	7.8	85
90				6.7	7.8	7.9	7.2	7.5	7.8	6.4	6.8	7.2	6.4	6.8	7.1	6.3	6.7	7	90
95				5.9	7.1	7.2	6.5	6.8	7	5.8	6.2	6.5	5.7	6.1	6.4	5.6	6	6.3	95
100				5.2	6.5		5.9	6.1	6.3	5.2	5.5	5.8	5.1	5.5	5.8	5	5.4	5.7	100
105				4.6	5.9		5.3	5.6		4.7	5	5.2	4.6	4.9	5.2	4.5	4.8	5.1	105
110				4.1	5.3		4.8	5		4.2	4.5	4.7	4.2	4.5	4.7	4	4.4	4.5	110
115				3.6	4.8		4.4	4.6		3.8	4		3.7	4	4.2	3.6	3.9	4.1	115
120				3			3.9	4.1		3.4	3.6		3.4	3.6		3.2	3.5		120
125							3.5	3.6		2.9	3.1		3	3.2		2.9	3.1		125
130							3.1			2.6	2.7		2.6	2.8		2.5	2.7		130
135										2.2	2.4		2.2	2.4		2.1	2.3		135
140										1.9			1.9	2		1.8	2		140
145										1.7			1.6			1.6			145
150													1.4						150

t_204_01144_01_000 / 01145_01_000 / 01146_01_000

Lifting capacities

Forces de levage

TK

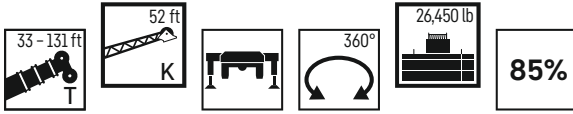

	33 ft			101 ft			112 ft			123 ft			129 ft			131 ft			
	0°	20°	40°	0°	20°	40°	0°	20°	40°	0°	20°	40°	0°	20°	40°	0°	20°	40°	
10	10.3																		10
11	10.2																		11
12	10.1																		12
13	10																		13
14	9.9																		14
15	9.8																		15
16	9.7																		16
17	9.5																		17
18	9.4																		18
19	9.3																		19
20	9.2			10.5															20
22	8.9	8.2		10.4			9.3												22
24	8.7	7.9		10.3			9.2												24
26	8.4	7.7		10.2			9.2			8.1									26
28	8.2	7.5		10.1			9.1			8.1			7.6			7.5			28
30	8	7.3		10			9			8.1			7.6			7.5			30
32	7.7	7.1		9.9			9			8			7.5			7.4			32
34	7.4	7		9.7			8.9			8			7.5			7.4			34
36	7.2	6.8	6.2	9.6	8		8.8			7.9			7.5			7.4			36
38	6.9	6.6	6	9.5	7.9		8.7			7.9			7.4			7.3			38
40	6.7	6.5	5.9	9.3	7.7		8.7	7.5		7.8			7.4			7.3			40
45	6.1	6.2	5.7	9	7.5		8.4	7.2		7.7	6.8		7.3			7.2			45
50	5.5	5.9	5.5	8.6	7.2	6.1	8.2	7		7.5	6.7		7.2	6.5		7.1	6.4		50
55	5.1	5.6	5.4	8.3	7	6	8	6.8	5.9	7.4	6.5		7.1	6.3		7	6.3		55
60	4.7	5.5	5.3	8	6.7	5.8	7.7	6.6	5.7	7.2	6.3	5.6	6.9	6.2		6.8	6.1		60
65	4.4	5.3	5.3	7.6	6.6	5.7	7.5	6.4	5.7	7.1	6.2	5.5	6.8	6.1	5.4	6.7	6	5.4	65
70	4.2	5.2	5.3	7.4	6.4	5.6	7.3	6.3	5.6	6.9	6.1	5.5	6.7	5.9	5.4	6.6	5.9	5.4	70
75	4	5.2		7.1	6.2	5.5	7.1	6.1	5.5	6.7	5.9	5.4	6.5	5.8	5.3	6.5	5.8	5.3	75
80				6.9	6.1	5.5	6.9	6	5.4	6.6	5.8	5.3	6.4	5.7	5.3	6.3	5.7	5.3	80
85				6.6	5.9	5.4	6.7	5.9	5.4	6.4	5.7	5.3	6.3	5.6	5.2	6.2	5.6	5.2	85
90				6.3	5.8	5.3	6.4	5.7	5.3	6.3	5.6	5.2	6.1	5.5	5.2	6.1	5.5	5.2	90
95				6	5.7	5.3	6.1	5.6	5.3	5.9	5.5	5.2	5.9	5.4	5.1	5.8	5.4	5.1	95
100				5.7	5.6	5.3	5.8	5.5	5.2	5.4	5.4	5.1	5.3	5.4	5.1	5.2	5.4	5.1	100
105				5.4	5.5	5.3	5.5	5.4	5.2	4.8	5.3	5.1	4.8	5.3	5.1	4.7	5.2	5.1	105
110				5.1	5.3	5.3	5	5.3	5.2	4.4	4.9	5.1	4.3	4.9	5.1	4.2	4.8	5.1	110
115				4.9	5.2	5.3	4.6	5	5.2	4	4.4	4.8	3.9	4.4	4.8	3.8	4.3	4.7	115
120				4.6	4.9	5	4.2	4.6	4.8	3.6	4	4.4	3.5	4	4.3	3.4	3.9	4.2	120
125				4.2	4.4	4.6	3.8	4.1	4.3	3.2	3.6	3.9	3.1	3.6	3.9	3	3.5	3.8	125
130				3.8	4	4.1	3.4	3.7	3.9	2.9	3.2	3.5	2.8	3.2	3.5	2.7	3.1	3.4	130
135				3.4	3.6		3.1	3.4	3.5	2.5	2.9	3.1	2.5	2.9	3.1	2.4	2.8	3	135
140				3.1	3.2		2.7	3		2.2	2.5	2.7	2.2	2.5	2.7	2.1	2.4	2.6	140
145				2.8			2.4	2.6		1.9	2.2	2.3	1.9	2.2	2.4	1.8	2.1	2.3	145
150							2.2	2.3		1.6	1.9		1.6	1.9	2	1.5	1.8	1.9	150
155							1.9			1.4	1.6		1.4	1.6		1.5	1.6	1.6	155

t_204_11144_01_000 / 11145_01_000 / 11146_01_000

Lifting capacities

Forces de levage

TK

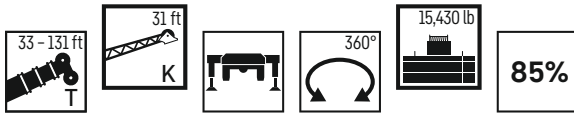

	33 ft			101 ft			112 ft			123 ft			129 ft			131 ft			
	31 ft																		
	0°	20°	40°	0°	20°	40°	0°	20°	40°	0°	20°	40°	0°	20°	40°	0°	20°	40°	
10	17.5																		10
11	17.1	16																	11
12	16.7	15.8																	12
13	16.4	15.5																	13
14	16	15.2																	14
15	15.6	14.9																	15
16	15.3	14.6																	16
17	14.9	14.4		18.5															17
18	14.5	14.1		18.5															18
19	14.2	13.8	12.6	18.5															19
20	13.8	13.6	12.4	18.5			16.3												20
22	13.1	13.1	12.1	18.5			16.3												22
24	12.4	12.7	11.7	18.3			16.2			13.5			12.3						24
26	10.9	12.3	11.4	18	15.5		16			13.5			12.3			12			26
28	9.1	11.9	11.1	17.6	15.2		15.9	14		13.5			12.3			12			28
30	8.8	11.6	10.8	17.3	14.9		15.7	13.9		13.4			12.3			12			30
32	8.8	11.2	10.5	16.9	14.6		15.6	13.7		13.3			12.2			12			32
34	8.1	10.9	10.2	16.5	14.4	12.3	15.4	13.5		13.3	12.2		12.2			11.9			34
36	7.4	10.5	9.9	16.1	14.1	12.1	15.2	13.3		13.1	12.1		12	11.4		11.8			36
38	6.7	10.2	9.4	15.8	13.9	11.9	15.1	13.1	11.6	13	12		11.9	11.3		11.7	11.2		38
40	6.1	9.9	9.2	15.4	13.6	11.8	14.9	12.9	11.4	12.9	11.8		11.7	11.3		11.6	11.1		40
45	4.7	8.9	8.8	14.5	13.1	11.4	13.9	12.5	11.2	12.3	11.5	10.6	11.3	10.9		11.2	10.8		45
50	3.6	8.4		13.1	12.6	11.1	12.1	12.1	10.8	11.8	11.2	10.3	10.9	10.4	9.9	10.7	10.4	9.5	50
55	2.6			11.3	11.8	10.8	11.3	11.3	10.5	10.4	10.7	10.1	10.1	9.8	9.3	9.9	9.8	9.3	55
60				10.5	10.6	10.4	9.9	10.1	10.2	9	9.8	9.4	9	9.1	8.9	8.8	9.1	8.9	60
65				9.1	9.3	9.8	8.7	9.2	9.2	7.9	8.6	9	7.8	8.4	8.5	7.7	8.3	8.5	65
70				8.1	8.6	8.6	7.7	8.2	8.6	6.9	7.5	8	6.8	7.4	7.9	6.7	7.3	7.8	70
75				7.1	7.6	7.9	6.8	7.2	7.6	6	6.6	7.1	6	6.5	7	5.8	6.4	6.9	75
80				6.3	6.7	7	5.9	6.4	6.7	5.3	5.8	6.2	5.2	5.7	6.2	5.1	5.6	6.1	80
85				5.6	5.9	6.1	5.2	5.6	5.9	4.6	5.1	5.4	4.6	5	5.4	4.4	4.9	5.3	85
90				4.9	5.2	5.4	4.6	4.9	5.2	4	4.4	4.8	4	4.4	4.7	3.9	4.3	4.6	90
95				4.3	4.6	4.7	4	4.3	4.5	3.5	3.9	4.1	3.4	3.8	4.1	3.3	3.7	4	95
100				3.8	4		3.5	3.7	3.9	3	3.3	3.5	3	3.3	3.6	2.9	3.2	3.5	100
105				3.3	3.5		3	3.3		2.5	2.8	3	2.5	2.8	3	2.5	2.8	3	105
110				2.9	3.1		2.6	2.8		2.1	2.4	2.6	2.1	2.4	2.6	2	2.3	2.5	110
115				2.6	2.7		2.2	2.4		1.7	2		1.7	2	2.2	1.7	1.9	2.1	115
120				2.2			1.9	2.1		1.4	1.6		1.4	1.6			1.6		120
125							1.6	1.7											125
130							1.3												130

t_204_01033_00_000 / 01042_00_000 / 01051_00_000

Lifting capacities

Forces de levage

TK

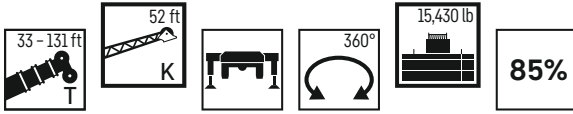

	33 ft			101 ft			112 ft			123 ft			129 ft			131 ft			
	0°	20°	40°	0°	20°	40°	0°	20°	40°	0°	20°	40°	0°	20°	40°	0°	20°	40°	
10	9.4																		10
11	9.3																		11
12	9.2																		12
13	9.1																		13
14	9																		14
15	8.9																		15
16	8.8																		16
17	8.7																		17
18	8.6																		18
19	8.5																		19
20	8.3			9.6															20
22	8.1	7.4		9.5			8.4												22
24	7.9	7.2		9.4			8.4												24
26	7.7	7		9.3			8.4			7.4									26
28	7.5	6.8		9.2			8.3			7.4			6.9			6.8			28
30	7.2	6.7		9.1			8.2			7.3			6.9			6.8			30
32	7	6.5		9			8.2			7.3			6.8			6.8			32
34	6.8	6.3		8.9			8.1			7.2			6.8			6.7			34
36	6.5	6.2	5.6	8.7	7.3		8			7.2			6.8			6.7			36
38	6.3	6	5.5	8.6	7.2		8			7.2			6.7			6.7			38
40	6.1	5.9	5.4	8.5	7.1		7.9	6.8		7.1			6.7			6.6			40
45	5.5	5.6	5.2	8.2	6.8		7.7	6.6		7	6.2		6.6			6.5			45
50	5	5.4	5	7.9	6.6	5.6	7.5	6.4		6.9	6.1		6.5	5.9		6.4	5.8		50
55	4.6	5.1	4.9	7.5	6.3	5.4	7.3	6.2	5.3	6.7	5.9		6.4	5.7		6.3	5.7		55
60	4.3	5	4.8	7.2	6.1	5.3	7.1	6	5.2	6.6	5.8	5.1	6.3	5.6		6.2	5.6		60
65	4	4.9	4.8	6.9	6	5.2	6.8	5.8	5.1	6.4	5.6	5	6.2	5.5	5	6.1	5.5	5	65
70	3.8	4.8	4.8	6.7	5.8	5.1	6.6	5.7	5	6.3	5.5	4.9	6.1	5.4	4.9	6	5.4	4.9	70
75	3.6	4.7		6.5	5.7	5	6.2	5.6	5	6.1	5.4	4.9	5.8	5.3	4.8	5.7	5.3	4.8	75
80				6.1	5.5	5	6	5.4	4.9	5.5	5.3	4.8	5.3	5.2	4.8	5.2	5.2	4.8	80
85				5.8	5.4	4.9	5.5	5.3	4.9	4.8	5.2	4.8	4.7	5.1	4.7	4.6	5.1	4.7	85
90				5.2	5.2	4.9	4.9	5.2	4.8	4.2	4.9	4.7	4.1	4.8	4.7	4	4.7	4.7	90
95				4.7	5	4.8	4.3	4.9	4.8	3.7	4.4	4.7	3.6	4.3	4.7	3.5	4.2	4.7	95
100				4.1	4.6	4.8	3.8	4.4	4.7	3.2	3.9	4.4	3.2	3.8	4.3	3	3.7	4.2	100
105				3.7	4.1	4.4	3.3	3.8	4.2	2.8	3.4	3.9	2.7	3.3	3.8	2.6	3.2	3.7	105
110				3.2	3.7	3.9	2.9	3.4	3.7	2.4	3	3.4	2.4	2.9	3.4	2.3	2.8	3.3	110
115				2.9	3.2	3.5	2.5	3	3.2	2.1	2.6	2.9	2	2.5	2.9	1.9	2.4	2.8	115
120				2.5	2.8	3	2.2	2.6	2.8	1.7	2.2	2.5	1.7	2.2	2.5	1.6	2.1	2.4	120
125				2.2	2.5	2.6	1.9	2.2	2.4	1.4	1.8	2.1	1.4	1.8	2.1	1.8	2.1	2.1	125
130				1.9	2.1	2.2	1.6	1.9	2		1.5	1.7		1.5	1.7		1.5	1.7	130
135				1.7	1.8		1.3	1.6	1.7			1.4		1.4			1.4		135
140				1.4	1.5														140

t_204_11033_00_000 / 11042_00_000 / 11051_00_000

Lifting capacities

Forces de levage

TK

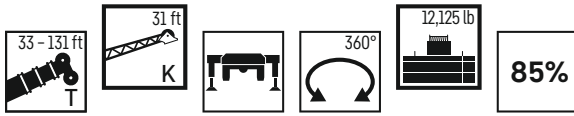

	33 ft			101 ft			112 ft			123 ft			129 ft			131 ft			
	0°	20°	40°	0°	20°	40°	0°	20°	40°	0°	20°	40°	0°	20°	40°	0°	20°	40°	
10	17.5																		10
11	17.1	16																	11
12	16.7	15.8																	12
13	16.4	15.5																	13
14	16	15.2																	14
15	15.6	14.9																	15
16	15.3	14.6																	16
17	14.9	14.4																	17
18	14.5	14.1				18.5													18
19	14.2	13.8				18.5													19
20	13.8	13.6				18.5													20
22	13.1	13.1				18.5													22
24	12.4	12.7				18.3													24
26	10.9	12.3				18													26
28	9.1	11.9				17.6													28
30	8.8	11.6				17.3													30
32	8.8	11.2				16.9													32
34	8.1	10.9				16.5													34
36	7.4	10.5				16.1													36
38	6.7	10.2				15.8													38
40	6.1	9.9				15.4													40
45	4.7	8.9				13.7													45
50	3.6	8.4				12.1													50
55	2.6					10.8													55
60						9.5													60
65						8.3													65
70						7.3													70
75						6.4													75
80						5.5													80
85						4.9													85
90						4.2													90
95						3.7													95
100						3.2													100
105						2.8													105
110						2.4													110
115						2.1													115
120						1.8													120

t_204.01036.00_000 / 01045.00_000 / 01054.00_000



	33 ft			101 ft			112 ft			123 ft			129 ft			131 ft			
	0°	20°	40°	0°	20°	40°	0°	20°	40°	0°	20°	40°	0°	20°	40°	0°	20°	40°	
10	9.4																		10
11	9.3																		11
12	9.2																		12
13	9.1																		13
14	9																		14
15	8.9																		15
16	8.8																		16
17	8.7																		17
18	8.6																		18
19	8.5																		19
20	8.3					9.6													20
22	8.1	7.4				9.5													22
24	7.9	7.2				9.4													24
26	7.7	7				9.3													26
28	7.5	6.8				9.2													28
30	7.2	6.7				9.1													30
32	7	6.5				8.9													32
34	6.8	6.3				8.7													34
36	6.5	6.2				8.7	7.3												36
38	6.3	6				8.6	7.2												38
40	6.1	5.9				8.5	7.1												40
45	5.5	5.6				8.2	6.8												45
50	5	5.4				7.9	6.6												50
55	4.6	5.1				7.5	6.4												55
60	4.3	5				7.3	6.2												60
65	4	4.9				7.1	6												65
70	3.8	4.8				6.9	5.8												70
75	3.6	4.7				6.7	5.8												75
80						6.5	5.7												80
85						6.3	5.5												85
90						6.1	5.4												90
95						5.9	5.4												95
100						5.7	5.3												100
105						5.5	5.2												105
110						5.3	5.1												110
115						5.1	5												115
120						4.9	4.9												120
125						4.7	4.7												125
130						4.5	4.6												130
135						4.3	4.5												135

t_204.01036.00_000 / 11045.00_000 / 11054.00_000

Lifting capacities

Forces de levage

TK

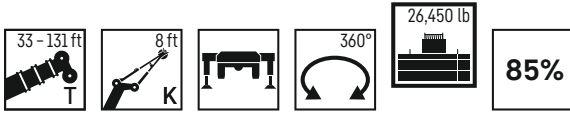

	33 ft	45 ft	56 ft	67 ft	78 ft	90 ft	101 ft	112 ft	123 ft	131 ft	
	8 ft										
10	39	39	39	39							10
11	39	39	39	39							11
12	39	39	39	39							12
13	39	39	39	39	39						13
14	39	39	39	39	39						14
15	39	39	39	39	39						15
16	39	39	39	39	39	39					16
17	39	39	39	39	39	39					17
18	39	39	39	39	39	39					18
19	39	39	39	39	39	39					19
20	38.3	39	39	39	39	39	38.5				20
22	35.4	39	39	39	39	39	37.6				22
24	32.4	39	39	39	39	39	36.6	29.5			24
26	29.2	39	39	39	39	38.9	35.5	28.9	23.5		26
28	26.8	37.1	39	39	38.8	37.5	34.2	28.1	23.1	19.7	28
30	24.4	34.8	38.5	38.1	36.3	34.5	32.7	27.2	22.6	19.4	30
32	22.3	32.4	36.2	35.7	33.7	32.4	30.7	26.4	21.9	19	32
34		30	33.7	33	31.2	30.1	28.5	25.6	21.3	18.6	34
36		27.9	32.1	30.7	29	28	26.4	24.9	20.7	18.2	36
38		26.1	30	28.7	27	26.2	24.7	23.8	20.2	17.8	38
40		24.3	28.1	26.8	25.5	24.9	23.7	22.7	19.7	17.4	40
45			23.9	23	21.9	21.6	20.6	19.6	18.4	16.5	45
50			20.3	20.1	19.8	18.8	17.9	17.4	16.9	15.6	50
55			17.6	17.3	17.6	16.5	16	15.7	14.8	14.5	55
60				15.1	15.5	14.5	14.3	13.9	13	12.9	60
65				14	13.6	13.2	13	12.4	11.5	11.4	65
70					12.1	12.1	11.7	11.1	10.2	10.2	70
75					10.9	10.9	10.4	9.9	9.1	9.1	75
80						9.5	9.1	8.8	8.2	8.1	80
85						8.6	8.2	7.9	7.3	7.3	85
90							7.4	7.1	6.6	6.5	90
95							6.7	6.4	5.9	5.9	95
100							6.1	5.8	5.3	5.3	100
105								5.2	4.7	4.7	105
110								4.7	4.1	4.2	110
115									3.7	3.7	115
120									3.2	3.2	120
125										2.8	125
130										2.5	130

t_204_01147_01_000

Lifting capacities

Forces de levage

TK

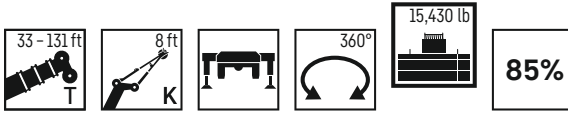

	33 ft	45 ft	56 ft	67 ft	78 ft	90 ft	101 ft	112 ft	123 ft	131 ft	
	8 ft										
10	39	39	39	39							10
11	39	39	39	39							11
12	39	39	39	39							12
13	39	39	39	39	39						13
14	39	39	39	39	39						14
15	39	39	39	39	39						15
16	39	39	39	39	39	39					16
17	39	39	39	39	39	39					17
18	39	39	39	39	39	39					18
19	39	39	39	39	39	39					19
20	38.3	39	39	39	39	39	35				20
22	35.5	39	39	39	39	38.9	34.2				22
24	32.4	39	39	38.6	38.5	36.3	33.1	26.8			24
26	29.2	38.8	37.9	37.7	35.4	33.5	30.8	26.2	21.4		26
28	26.8	35.1	34.8	34.3	32.1	30.8	28.5	25.5	21	17.9	28
30	24.4	31.4	32.1	31.4	29.4	28.2	26.3	24.8	20.6	17.6	30
32	22.4	28.6	29	28.7	27.3	26.5	24.8	23.5	20	17.3	32
34		26	26.3	26.2	25.1	24.5	23.3	21.8	19.4	16.9	34
36		23.7	24	23.9	23.5	22.7	21.5	20.2	18.8	16.6	36
38		21.8	22.1	21.9	22.3	21	20	18.9	18.4	16.2	38
40		20	20.3	20.2	20.7	19.6	18.6	18.3	17.3	15.8	40
45			16.8	17.2	17	16.5	16.4	15.7	14.7	14.5	45
50			14.1	14.6	14.3	14.4	14.2	13.5	12.6	12.4	50
55			12	12.4	12.3	12.3	12.1	11.7	10.8	10.7	55
60				10.8	10.7	10.6	10.4	10.2	9.4	9.3	60
65				9.4	9.3	9.3	9	8.8	8.1	8.1	65
70					8.2	8.2	7.9	7.6	7.1	7	70
75					7.2	7.2	6.9	6.6	6.2	6.2	75
80						6.4	6.1	5.8	5.3	5.4	80
85						5.6	5.3	5.1	4.6	4.6	85
90							4.6	4.4	3.9	4	90
95							4.1	3.8	3.3	3.4	95
100							3.6	3.3	2.8	2.9	100
105								2.9	2.4	2.4	105
110								2.5	1.9	2	110
115									1.6	1.6	115

t_204_01060_00_000

Lifting capacities

Forces de levage

TK

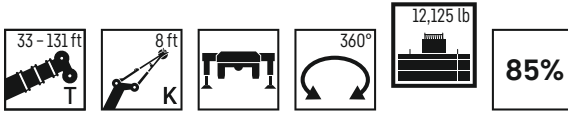

	33 ft	45 ft	56 ft	67 ft	78 ft	90 ft	101 ft	112 ft	123 ft	131 ft	
	8 ft										
10	39	39	39	39							10
11	39	39	39	39							11
12	39	39	39	39							12
13	39	39	39	39	39						13
14	39	39	39	39	39						14
15	39	39	39	39	39						15
16	39	39	39	39	39	39					16
17	39	39	39	39	39	39					17
18	39	39	39	39	39	39					18
19	39	39	39	39	39	39					19
20	38.3	39	39	39	39	39	35				20
22	35.5	39	39	38.9	39	36.8	33.8				22
24	32.4	39	38.4	38.1	36.5	34.3	30.9	26.8			24
26	29.2	37.1	36	35.1	33	31.4	28.4	26.2	21.4		26
28	26.8	32.8	33.5	31.9	30.1	28.7	26.9	24.8	21	17.9	28
30	24.4	29.6	30.1	29	27.4	26.7	25.1	23.1	20.6	17.6	30
32	22.4	26.7	27.1	26.5	25.5	24.4	23.1	21.5	20	17.3	32
34		24.2	24.6	24.3	24	22.5	21.3	20.3	19.3	16.9	34
36		22	22.3	22.2	22.2	20.8	20.1	19.4	18.2	16.6	36
38		20	20.4	20.5	20.6	19.2	18.8	18.2	16.9	16.2	38
40		18.3	18.7	19.2	19	17.9	17.8	16.9	15.8	15.4	40
45			15.4	15.8	15.6	15.8	15	14.3	13.2	13.1	45
50			12.9	13.3	13.2	13.2	12.9	12.2	11.3	11.2	50
55			10.9	11.3	11.3	11.2	11	10.5	9.7	9.6	55
60				9.8	9.7	9.7	9.4	9.1	8.3	8.2	60
65				8.5	8.4	8.4	8.1	7.9	7.1	7.1	65
70					7.3	7.3	7.1	6.8	6.2	6.1	70
75					6.5	6.4	6.1	5.9	5.3	5.3	75
80						5.6	5.3	5	4.6	4.6	80
85						4.9	4.6	4.3	3.9	3.9	85
90							4	3.7	3.2	3.3	90
95							3.5	3.2	2.7	2.8	95
100							3	2.7	2.2	2.3	100
105								2.3	1.8	1.9	105
110								1.9			110

t_204_01063_00_000

Equipment

Crane carrier

Frame	Liebherr designed and manufactured, box-type, torsion resistant design of hightensile fine grained structural steel.
Outriggers	4-point supporting system, hydraulically telescopic into horizontal and vertical direction. Operation with remote control, automatic support leveling, electronic inclination display.
Engine	6-cylinder Diesel, make Liebherr, watercooled, output 270 kW (367 h.p.), max. torque 1407 lb-ft. Exhaust emissions to (EU 2016/1628 and EPA/CARB or ECE-R.96, spark arrestor. Fuel reservoir: 92 gallons.
Transmission	ZF 12-speed gear box with automatic control system. Two-stage transfer case with lockable transfer differential.
Axles	All axles steered, axle 2 and 3 driven with lockable differential gears.
Suspension	All axles with hydropneumatic suspension and hydraulic locking facility.
Tyres	6 tyres. Tyre size: 445/95 R 25 (16.00 R 25).
Steering	2-circuit system with hydraulic servo steering. Active speed depending rear axle steering, special steering programs for various driving situations.
Brakes	Service brake: all-wheel servo-air brake, all axles are equipped with disc brakes, dual circuit. Hand brake: Spring-loaded, acting on all wheels of axles 1, 2 and 3. Sustained-action brake: Exhaust retarder with additional Liebherr braking system.
Driver's cab	Spacious corrosion resistant with comfort furnishings, mounted on rubber shock absorbers, safety glazing.
Electrical system	Modern data bus technique, 24 Volt DC.

Crane superstructure

Frame	Liebherr-made, torsion-resistant, welded construction of high-tensile structural steel, single-row ball bearing slewing ring.
Crane drive	Diesel-hydraulic with 1 axial variable displacement pump with automatic capacity control, 1 double gear pump, driven by the carrier Diesel engine, open regulated oil circuits with electrically controlled "load sensing", operation of 4 movements simultaneously.
Control	Electrical control of drives by self-centering joysticks, armrest-integrated control elements, Liebherr system bus (LSB).
Hoist gear	Axial piston fixed displacement motor, hoist drum with integrated planetary gear and spring-loaded static brake, actuation by open regulated oil circuit.
Luffing gear	1 differential ram with pilot operated brake valve.
Slewing gear	Axial piston fixed displacement motor, planetary gear, spring-loaded static brake. Slewing gear invertible from released to locked as a standard feature.
Crane cab	Large screen area, compound glass, comfort furnishing, cabin tiltable 20° to rear.
Safety devices	LICCON2 safe load indicator, hoist limit switch, safety valves against pipe and hose rupture, test system for servicing.
Telescopic boom	1 base section and 4 telescopic sections. All telescopic sections extendable hydraulically and independently from one another. Rapid-cycle telescoping system TELEMATIK. Boom length: 33 ft - 131 ft.
Counterweight	15,430 lb
Electrical system	Modern data bus technique, 24 Volt DC.

Additional equipment

K	Single folding jib, 31 ft Double swing-away jib 31 ft - 52 ft Mechanical adjustment 0°, 20°, 40°
K	Assembly jib 8 ft
2nd hoist gear	For two-hook operation or for operation with swing-away jib if the hoist rope shall remain reeved.
Additional counterweight	11,020 lb for a total counterweight of 26,450 lb.
Tyres	6 tyres. Tyre size: 525/80 R 25 (20.5 R 25).
Drive 6 x 6	Axle 1 additionally driven.
Other items of equipment available on request.	

Équipement

Châssis porteur

Cadre	Fabrication Liebherr, construction en caisson indéformable, en acier à haute résistance à grains fins.
Calage	Dispositif de calage horizontal et vertical en 4 points, entièrement déployable hydrauliquement. Utilisation avec commande à distance, mise à niveau automatique du calage, inclinomètre électronique.
Moteur	Moteur diesel, 6 cylindres, fabriqué par Liebherr, à refroidissement par eau, de 270 kW (367 ch), couple max. 1407 lb-ft. Emissions des gaz d'échappement conformes aux directives (EU) 2016/1628 et EPA/CARB ou ECE-R.96, pare-étincelles. Capacité du réservoir à carburant: 92 gallons.
Boîte de vitesse	Boîte de vitesses ZF à 12 rapports, mécanisme automatisé à commande. Boîte de transfert à 2 étages avec blocage de différentiel.
Essieux	Tous les essieux sont directeurs, les essieux 2 et 3 sont entraînés par des engrenages différentiels blocables.
Suspension	Tous les essieux sont suspendus hydropneumatiquement et blocable hydrauliquement.
Pneumatiques	6 roues. Taille: 445/95 R 25 (16.00 R 25).
Direction	2 circuits avec direction assistée hydraulique. Direction active des essieux arrière et dépendante de la vitesse, programmes de direction spéciaux pour les différents modes de déplacement.
Freins	Freins de service: servofrein à air comprimé, tous les essieux sont munis de freins à disque, à 2 circuits. Frein à main: par cylindres à ressorts, agissant sur les roues des essieux 1, 2 et 3. Frein à régime continu: Ralentisseur sur échappement avec système de freinage additionnel Liebherr.
Cabine	Spacieuse cabine, traitement anticorrosion, équipement «grand confort», suspension par silentblochs, vitrage de sécurité.
Installation électrique	Technique moderne de transmission de données par BUS de données, courant continu 24 Volts.

Partie tournante

Cadre	Fabrication Liebherr, construction mécano-soudée en tôle d'acier à haute résistance à grains fins. Couronne d'orientation à 1 rangée de billes.
Entraînement	Diesel hydraulique avec 1 pompe double à débit variable et régulation de puissance automatique, 1 pompe à engrenages double, entraînés par le moteur Diesel du porteur, circuits hydrauliques ouverts avec «load sensing», régulé électriquement. 4 mouvements simultanés praticables.
Commande	Commande électrique des mécanismes par leviers de manoeuvre à centrage automatique, commandes de grue „grand confort“ intégrées aux accoudoirs du siège, Liebherr système bus.
Mécanisme de levage	Moteur hydraulique à cylindrée constante, treuil à réducteur planétaire incorporé et frein d'arrêt à ressort, en circuit hydraulique ouvert ou fermé et régulé.
Mécanisme de relevage	1 vérin différentiel avec clapet de frein commandé.
Dispositif de rotation	Moteur à cylindrée constante à pistons axiaux, engrenage planétaire, frein d'arrêt commandé par ressort. Orientation de série commutable en circuit hydraulique ouvert ou fermé (freinage automatique ou au pied).
Cabine de grue	Large champ de vision, vitrage de sécurité, équipement pour un confort idéal, cabine inclinable de 20° vers l'arrière.
Dispositif de sécurité	Contrôleur de charge LICCON2, fin de course crochet haut, clapets de sécurité en cas de ruptures de flexibles. Système de test pour faciliter l'entretien.
Flèche télescopique	1 élément de base et 4 éléments télescopiques. Chaque élément télescopable indépendamment de l'autre. Système de télescopage TELEMATIK séquentiel rapide. Longueur de flèche: 33 ft - 131 ft.
Contrepoids	15,430 lb
Installation électrique	Technique moderne de transmission de données par BUS de données, courant continu 24 Volts.

Équipement supplémentaire

K	Fléchette pliante simple, longueur 31 ft Double fléchette pliante 31 ft - 52 ft Réglage mécanique à 0°, 20°, 40°
K	Fléchette de montage 8 ft
2ème mécanisme de levage	Pour l'utilisation du deuxième crochet, ou bien pour une utilisation avec fléchette pliante lorsque le câble de levage principal rest moufle.
Contrepoids additionnel	11,020 lb pour un contrepoids total de 26,450 lb.
Pneumatiques	6 roues. Taille: 525/80 R 25 (20.5 R 25).
Entraînement 6 x 6	Essieu 1 est entraîné additionnellement.

Autres équipements supplémentaires sur demande.

Description of symbols

Explication des symboles



Max. capacity
Capacité max.



Outriggers front
Calage avant



Radius
Portée



Max. hoist height
Hauteur de levage max.



Outriggers rear
Calage arrière



Telescopic boom
Flèche télescopique



Max. radius
Portée max.



Crane superstructure
Partie tournante de la grue



Swing away jib
Fléchette pliante



Tyres
Pneumatiques



infinitely variable
en continu



Assembly jib
Fléchette de montage



Hookblock/Capacity
Moufle à crochet/Capacité de charge



Rope diameter
Diamètre



No. of sheaves
Poulies



Rope length
Longueur du câble



No. of lines
Brins



Max. single line pull
Effort au brin maxi.



Weight
Poids



Hoist gear
Treuil de levage



Crane carrier
Châssis porteur



Slewing speeds
Vitesses d'orientation



Driving speed
Vitesse de translation



Boom length
Longueur de la flèche



Gradability
Aptitude à gravir les pentes



Boom position
Position de la flèche



Transmission
Boîte de vitesse



Counterweight
Contrepoids



Gear
Vitesse



Outriggers
Calage



Onroad gear
Vitesse de route



Outriggers - free on tyres
Calage - libre sur pneus



Crawl speed
Marche lente



Slewing gear / Working area
Mécanisme d'orientation / Plage de travail



Max. supporting forces
Forces d'appui max.



Standard
Norme

Remarks

1. The lifting capacities do not exceed 85 % of the tipping load according to ASME B 30.5. The crane's structural steelwork is in accordance with EN 13000 and ASME B 30.5.
2. For the calculation of the load charts at least a wind speed of 30 ft/s (9 m/s, 20 mph) and regarding the load a sail area of 1 m² per ton load and a wind resistance coefficient of 1.2 on the load have been taken into account. For lifting of loads with large sail areas and/or high wind resistance coefficients the maximum wind speed as stated in the load charts has to be reduced.
3. The lifting capacities stated are valid for lifting operation only (corresponding with crane classification according to ISO 4301-1, crane group A1).
4. Lifting capacities are given in kip.
5. The weight of the hook blocks and hooks is part of the load and therefore it must be deducted from the lifting capacities.
6. Working radii are measured from the slewing center.
7. The stated lengths of the telescopic boom are maximum values and may deviate slightly.
8. The lifting capacities given for the telescopic boom apply if the folding jib is removed.
9. Subject to modification of lifting capacities.
10. Lifting capacities above 93,300 lb only with additional pulley block.
11. The data of this brochure serves only for general information. All information is provided without warranty. Instructions for the correct commissioning of the crane please take from the operation manual and the load chart book.
12. The illustrations in this brochure may feature accessories and special equipment not included in the standard scope of delivery.

Remarques

1. La capacité de charge ne doit pas dépasser 85 % de la charge de basculement conformément à ASME B 30.5. La structure métallique de la grue est conforme à EN 13000 et ASME B 30.5.
2. Une vitesse de vent de 30 ft/s (9 m/s, 20 mph) minimum, une surface de prise au vent de 1 m² par tonne ainsi qu'un coefficient de résistance au vent de la charge 1,2 sont pris en compte pour le calcul des tableaux de charge. Lorsque des charges ayant une surface de prise au vent et/ou un coefficient de résistance au vent plus élevé(e)s sont levées, la vitesse de vent maximale indiquée dans les tableaux de charge doit être réduite.
3. Forces de levage pour application de grue de montage (correspond à la classification de grues selon ISO 4301-1, groupe de grues A1).
4. Les charges sont indiquées en kip.
5. Le poids du crochet de levage resp. de la moufle à crochet est une partie de la charge et doit donc être déduit de la capacité de charge.
6. Les portées sont calculées à partir de l'axe de rotation.
7. Les longueurs indiquées pour la flèche télescopique sont des valeurs maximales et peuvent légèrement varier dans la réalité.
8. Les charges indiquées pour la flèche télescopique sont valables lorsque la fléchette pliante est démontée.
9. Charges données sous réserve de modification.
10. Forces de levage plus de 93,300 lb seulement avec moufle additionnel.
11. Les données de cette brochure sont données à titre informatif. Ces renseignements sont sans garantie. Les consignes relatives à la bonne mise en service de la grue sont disponibles dans le manuel d'utilisation et le manuel de tableaux de charge.
12. Les figures contiennent également des accessoires et des équipements spéciaux non inclus de série dans la livraison.

Customer Service

Personal. Competent. Reliable.
Personnalisé. Compétent. Fiable.



To ensure your Liebherr remains a Liebherr.

- Commission and training by experienced service technicians
- Worldwide service network with over 80 branches
- 24/7 technical support worldwide
- Fast availability of spare parts
- Attractive packages for maintenance and service

De sorte que votre Liebherr reste une Liebherr.

- Mise en route et formation effectuées par des techniciens qualifiés
- Service-Après-Vente Mondial représenté par plus de 80 correspondants
- Assistance Technique 24/24 et 7/7 jours
- Rapide disponibilité des pièces de rechanges
- Kits d'entretiens pour révisions et maintenances à un prix attractif

Proposition 65



WARNING: This product can expose you to chemicals, including exhaust emissions, including lead and lead compounds, which are known to the State of California to cause cancer, birth defects or other reproductive harm.
For more information see: www.P65warnings.ca.gov/diesel

Subject to modification · Sous réserve de modifications

Liebherr-Werk Echingen GmbH · Postfach 1361 · 89582 Echingen, Germany
+49 73 91 5 02-0 · www.liebherr.com

Get Your
Contact



Printed in Germany (2)
lwe-td-204-03-us-10-2022